



2.5V or 3.3V, 200-MHz, 14 Output Zero Delay Buffer

General Features

- Output frequency range: 8.3MHz to 200MHz
- Input frequency range: 4.2MHz to 125MHz
- 2.5V or 3.3V operation
- Split 2.5V/3.3V outputs
- 14 Clock outputs: Drive up to 28 clock lines
- 1 Feedback clock output
- 2 LVCMOS reference clock inputs
- 150 pS max output-output skew
- PLL bypass mode
- 'SpreadTrak'
- Output enable/disable
- Industrial temperature range: -40°C to $+85^{\circ}\text{C}$
- 52 Pin 1.0 mm TQFP Package
- RoHS Compliance

Functional Description

The ASM5I9775A is a low-voltage high-performance 200 MHz PLL-based zero delay buffer designed for high-speed clock distribution applications. The ASM5I9775A features two reference clock inputs and provides

14 outputs partitioned in 3 banks of 5, 5, and 4 outputs. Bank A and Bank B divide the VCO output by 4 or 8 while Bank C divides by 8 or 12 per SEL(A:C) settings, see *Functional Table*. These dividers allow output to input ratios of 6:1, 4:1, 3:1, 2:1, 3:2, 4:3, 1:1, and 2:3. Each LVCMOS compatible output can drive 50Ω series or parallel terminated transmission lines. For series terminated transmission lines, each output can drive one or two traces giving the device an effective fanout of 1:28.

The PLL is ensured stable, given that the VCO is configured to run between 200 MHz and 500 MHz. This allows a wide range of output frequencies from 8.3 MHz to 200 MHz. For normal operation, the external feedback input, FB_IN, is connected to the feedback output, FB_OUT. The internal VCO is running at multiples of the input reference clock set by the feedback divider, see *Frequency Table*. When PLL_EN is LOW, PLL is bypassed and the reference clock directly feeds the output dividers. This mode is fully static and the minimum input clock frequency specification does not apply.

Block Diagram

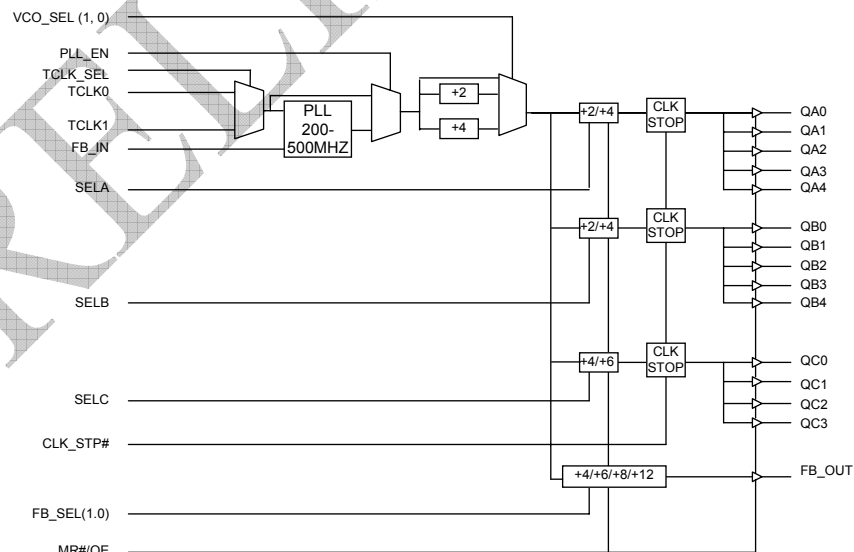



Pin Configuration

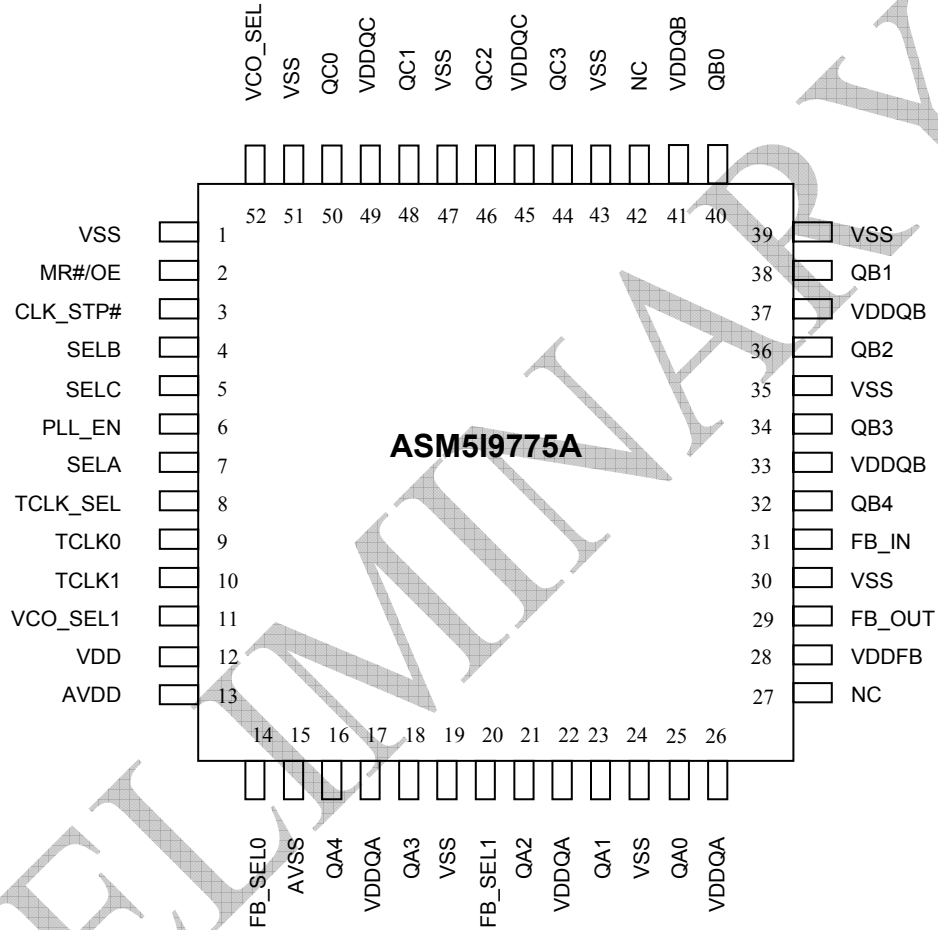



rev 0.3

Pin Description¹

Pin	Name	I/O	Type	Description
9	TCLK0	I, PD	LVC MOS	LVC MOS/LVTTL reference clock input
10	TCLK1	I, PU	LVC MOS	LVC MOS/LVTTL reference clock input
16, 18, 21, 23, 25	QA(4:0)	O	LVC MOS	Clock output bank A
32, 34, 36, 38, 40	QB(4:0)	O	LVC MOS	Clock output bank B
44, 46, 48, 50	QC(3:0)	O	LVC MOS	Clock output bank C
29	FB_OUT	O	LVC MOS	Feedback clock output. Connect to FB_IN for normal operation.
31	FB_IN	I, PU	LVC MOS	Feedback clock input. Connect to FB_OUT for normal operation. This input should be at the same voltage rail as input reference clock. See <i>Table 1</i> .
2	MR#/OE	I, PU	LVC MOS	Output enable/disable input. See <i>Table 2</i> .
3	CLK_STP#	I, PU	LVC MOS	Clock stop enable/disable input. See <i>Table 2</i> .
6	PLL_EN	I, PU	LVC MOS	PLL enable/disable input. See <i>Table 2</i> .
8	TCLK_SEL	I, PD	LVC MOS	Reference select input. See <i>Table 2</i> .
11, 52	VCO_SEL(1,0)	I, PD	LVC MOS	VCO divider select input. See <i>Tables 2, 3 and 4</i> .
7, 4, 5	SEL(A:C)	I, PD	LVC MOS	Frequency select input, Bank (A:C). See <i>Table 3</i> .
20, 14	FB_SEL(1,0)	I, PD	LVC MOS	Feedback dividers select inputs. See <i>Table 4</i> .
17, 22, 26	VDDQA	Supply	VDD	2.5V or 3.3V Power supply for bank A output clocks ^{2,3}
33, 37, 41	VDDQB	Supply	VDD	2.5V or 3.3V Power supply for bank B output clocks ^{2,3}
45, 49	VDDQC	Supply	VDD	2.5V or 3.3V Power supply for bank C output clocks ^{2,3}
28	VDDFB	Supply	VDD	2.5V or 3.3V Power supply for feedback output clock ^{2,3}
13	AVDD	Supply	VDD	2.5V or 3.3V Power supply for PLL ^{2,3}
12	VDD	Supply	VDD	2.5V or 3.3V Power supply for core and inputs ^{2,3}
15	AVSS	Supply	Ground	Analog Ground
1, 19, 24, 30, 35, 39, 43, 47, 51	VSS	Supply	Ground	Common Ground
27, 42	NC			No Connection

Notes:

1. PU = Internal pull-up, PD = Internal pull-down
2. A 0.1µF bypass capacitor should be placed as close as possible to each positive power pin (<0.2"). If these bypass capacitors are not close to the pins their high frequency filtering characteristics will be cancelled by the lead inductance of the traces.
3. AVDD and VDD pins must be connected to a power supply level that is at least equal or higher than that of VDDQA, VDDQB, VDDQC, and VDDFB power supply pins.



rev 0.3

'SpreadTrak'

Many systems being designed now utilize a technology called Spread Spectrum Frequency Timing Generation. ASM5I9775A is designed so as not to filter off the Spread Spectrum feature of the Reference Input, assuming it exists.

When a zero delay buffer is not designed to pass the Spread Spectrum feature through, the result is a significant amount of tracking skew which may cause problems in the systems requiring synchronization.

Table 1. Frequency Table

Feedback Output Divider	VCO	Input Frequency Range (AVDD = 3.3V)	Input Frequency Range (AVDD = 2.5V)
÷8	Input Clock * 8	25 MHz to 62.5 MHz	25 MHz to 50 MHz
÷12	Input Clock * 12	16.6 MHz to 41.6 MHz	16.6 MHz to 33.3 MHz
÷16	Input Clock * 16	12.5 MHz to 31.25 MHz	12.5 MHz to 25 MHz
÷24	Input Clock * 24	8.3 MHz to 20.8 MHz	8.3 MHz to 16.6 MHz
÷32	Input Clock * 32	6.25 MHz to 15.625 MHz	6.25 MHz to 12.5 MHz
÷48	Input Clock * 48	4.2 MHz to 10.4 MHz	4.2 MHz to 8.3 MHz
÷4	Input Clock * 4	50 MHz to 125 MHz	50 MHz to 100 MHz
÷6	Input Clock * 6	33.3 MHz to 83.3 MHz	33.3 MHz to 66.6 MHz
÷8	Input Clock * 8	25 MHz to 62.5 MHz	25 MHz to 50 MHz
÷12	Input Clock * 12	16.6 MHz to 41.6 MHz	16.6 MHz to 33.3 MHz

Table 2. Function Table (Configuration controls)

Control	Default	0	1
TCLK_SEL	0	TCLK0	TCLK1
VCO_SEL0	0	VCO÷2 (mid input frequency range)	VCO÷4 (low input frequency range)
VCO_SEL1	0	Gated by VCO_SEL0	VCO (high input frequency range)
PLL_EN	1	Bypass mode, PLL disabled. The input clock connects to the output dividers	PLL enabled. The VCO output connects to the output dividers
$\overline{\text{MR/OE}}$	1	Outputs disabled (three-state) and reset of the device. During reset/output disable the PLL feedback loop is open and the VCO running at its minimum frequency. The device is reset by the internal power-on reset (POR) circuitry during power-up.	Outputs enabled
$\overline{\text{CLK_STP}}$	1	QA, QB, and QC outputs disabled in LOW state. FB_OUT is not affected by CLK_STP.	Outputs enabled



rev 0.3

Table 3. Function Table (Bank A, B, and C)

VCO_SEL1	VCO_SEL0	SELA	QA(4:0)	SELB	QB(4:0)	SELC	QC(3:0)
0	0	0	÷4	0	÷4	0	÷8
0	0	1	÷8	1	÷8	1	÷12
0	1	0	÷8	0	÷8	0	÷16
0	1	1	÷16	1	÷16	1	÷24
1	x	0	÷2	0	÷2	0	÷4
1	x	1	÷4	1	÷4	1	÷6

Table 4. Function Table (FB_OUT)

VCO_SEL1	VCO_SEL0	FB_SEL1	FB_SEL0	FB_OUT
0	0	0	0	÷8
0	0	0	1	÷16
0	0	1	0	÷12
0	0	1	1	÷24
0	1	0	0	÷16
0	1	0	1	÷32
0	1	1	0	÷24
0	1	1	1	÷48
1	x	0	0	÷4
1	x	0	1	÷8
1	x	1	0	÷6
1	x	1	1	÷12

Absolute Maximum Conditions

Parameter	Description	Condition	Min	Max	Unit
VDD	DC Supply Voltage		-0.3	5.5	V
VDD	DC Operating Voltage	Functional	2.375	3.465	V
V _{IN}	DC Input Voltage	Relative to VSS	-0.3	VDD+ 0.3	V
V _{OUT}	DC Output Voltage	Relative to VSS	-0.3	VDD+ 0.3	V
V _{TT}	Output termination Voltage		-	VDD ÷2	V
LU	Latch Up Immunity	Functional	200	-	mA
R _{PS}	Power Supply Ripple	Ripple Frequency < 100 kHz	-	150	mVp-p
T _S	Temperature, Storage	Non Functional	-65	+150	°C
T _A	Temperature, Operating Ambient	Functional	-40	+85	°C
T _J	Temperature, Junction	Functional	-	150	°C
Ø _{JC}	Dissipation, Junction to Case	Functional	-	23	°C/W
Ø _{JA}	Dissipation, Junction to Ambient	Functional	-	55	°C/W
ESD _H	ESD Protection (Human Body Model)		2000	-	Volts
FIT	Failure in Time	Manufacturing test		10	ppm



rev 0.3

DC Electrical Specifications (VDD= 3.3V ± 5%, T_A = -40°C to +85°C)

Parameter	Description	Condition	Min	Typ	Max	Unit
V _{IL}	Input Voltage, Low	LVC MOS	-	-	0.8	V
V _{IH}	Input Voltage, High	LVC MOS	2.0	-	VDD+0.3	V
V _{OL}	Output Voltage, Low ⁴	I _{OL} = 24 mA	-	-	0.55	V
		I _{OL} = 12 mA	-	-	0.30	
V _{OH}	Output Voltage, High ⁴	I _{OH} = -24 mA	2.4	-	-	V
I _{IL}	Input Current, Low ⁵	V _{IL} = VSS	-	-	-100	μA
I _{IH}	Input Current, High ⁵	V _{IL} = VDD	-	-	100	μA
I _{DDA}	PLL Supply Current	AVDD only	-	5	10	mA
I _{DDQ}	Quiescent Supply Current	All VDD pins except AVDD	-	-	1	mA
I _{DD}	Dynamic Supply Current	Outputs loaded @ 100 MHz	-	225	-	mA
		Outputs loaded @ 200 MHz	-	290	-	
C _{IN}	Input Pin Capacitance		-	4	-	pF
Z _{OUT}	Output Impedance		12	15	18	Ω

DC Electrical Specifications (VDD= 2.5V ± 5%, T_A = -40°C to +85°C)

Parameter	Description	Condition	Min.	Typ.	Max	Unit
V _{IL}	Input Voltage, Low	LVC MOS	-	-	0.7	V
V _{IH}	Input Voltage, High	LVC MOS	1.7	-	VDD+0.3	V
V _{OL}	Output Voltage, Low ⁴	I _{OL} = 15 mA	-	-	0.6	V
V _{OH}	Output Voltage, High ⁴	I _{OH} = -15 mA	1.8	-	-	V
I _{IL}	Input Current, Low ⁵	V _{IL} = VSS	-	-	-100	μA
I _{IH}	Input Current, High ⁵	V _{IL} = VDD	-	-	100	μA
I _{DDA}	PLL Supply Current	AVDD only	-	5	10	mA
I _{DDQ}	Quiescent Supply Current	All VDD pins except AVDD	-	-	1	mA
I _{DD}	Dynamic Supply Current	Outputs loaded @ 100 MHz	-	135	-	mA
		Outputs loaded @ 200 MHz	-	160	-	
C _{IN}	Input Pin Capacitance		-	4	-	pF
Z _{OUT}	Output Impedance		14	18	22	Ω

Notes:

4. Driving one 50Ω parallel terminated transmission line to a termination voltage of V_{TT}. Alternatively, each output drives up to two 50Ω series terminated transmission lines.
5. Inputs have pull-up or pull-down resistors that affect the input current.



rev 0.3

AC Electrical Specifications⁶ (VDD= 2.5V ± 5%, T_A = -40°C to +85°C)

Parameter	Description	Condition	Min	Typ	Max	Unit
f _{VCO}	VCO Frequency		200	-	400	MHz
f _{in}	Input Frequency	÷4 Feedback	50	-	100	MHz
		÷6 Feedback	33.3	-	66.6	
		÷8 Feedback	25	-	50	
		÷12 Feedback	16.7	-	33.3	
		÷16 Feedback	12.5	-	25	
		÷24 Feedback	8.3	-	16.7	
		÷32 Feedback	6.3	-	12.5	
		÷48 Feedback	4.2	-	8.3	
	Bypass mode (PLL_EN = 0)	0	-	200		
f _{refDC}	Input Duty Cycle		25	-	75	%
t _r , t _f	TCLK Input Rise/Fall Time	0.7V to 1.7V	-	-	1.0	nS
f _{MAX}	Maximum Output Frequency	÷2 Output	100	-	200	MHz
		÷4 Output	50	-	100	
		÷6 Output	33.3	-	66.6	
		÷8 Output	25	-	50	
		÷12 Output	16.7	-	33.3	
		÷16 Output	12.5	-	25	
		÷24 Output	8.3	-	16.7	
DC	Output Duty Cycle		45	-	55	%
t _r , t _f	Output Rise/Fall times	0.7V to 1.8V	0.1	-	1.0	nS
t _(φ)	Propagation Delay (static phase offset)	TCLK to FB_IN, does not include jitter	-100	-	100	pS
t _{sk(O)}	Output-to-Output Skew	Skew within Bank	-	-	150	pS
t _{sk(B)}	Bank-to-Bank Skew	Banks at same frequency	-	-	150	pS
		Banks at different frequency	-	-	225	
t _{PLZ, HZ}	Output Disable Time		-	-	10	nS
t _{PZL, ZH}	Output Enable Time		-	-	10	nS
BW	PLL Closed Loop Bandwidth (-3 dB)	VCO_SEL = 0	-	0.5 - 1.0	-	MHz
		VCO_SEL = 1	-	1.0 - 2.0	-	
t _{JIT(CC)}	Cycle-to-Cycle Jitter	Same frequency	-	-	150	pS
		Multiple frequencies	-	-	300	
t _{JIT(PER)}	Period Jitter		-	-	100	pS
t _{JIT(φ)}	I/O Phase Jitter		-	-	150	pS
t _{LOCK}	Maximum PLL Lock Time		-	-	1	mS

Note:6. AC characteristics apply for parallel output termination of 50Ω to V_{TT}. Parameters are guaranteed by characterization and are not 100% tested.



rev 0.3

AC Electrical Specifications ⁶ ($V_{DD} = 3.3V \pm 5\%$, $T_A = -40^\circ C$ to $+85^\circ C$)

Parameter	Description	Condition	Min	Typ	Max	Unit
f_{VCO}	VCO Frequency		200	-	500	MHz
f_{in}	Input Frequency	+4 Feedback	50	-	125	MHz
		+6 Feedback	33.3	-	83.3	
		+8 Feedback	25	-	62.5	
		+12 Feedback	16.7	-	41.6	
		+16 Feedback	12.5	-	31.3	
		+24 Feedback	8.3	-	20.8	
		+32 Feedback	6.3	-	15.6	
		+48 Feedback	4.2	-	10.4	
	Bypass mode (PLL_EN = 0)	0	-	200		
f_{refDC}	Input Duty Cycle		25	-	75	%
t_r, t_f	TCLK Input Rise/Fall Time	0.8V to 2.0V	-	-	1.0	nS
f_{MAX}	Maximum Output Frequency	+2 Output	100	-	200	MHz
		+4 Output	50	-	125	
		+6 Output	33.3	-	83.3	
		+8 Output	25	-	62.5	
		+12 Output	16.7	-	41.6	
		+16 Output	12.5	-	31.3	
		+24 Output	8.3	-	20.8	
DC	Output Duty Cycle		45	-	55	%
t_r, t_f	Output Rise/Fall times	0.8V to 2.4V	0.1	-	1.0	nS
$t_{(\phi)}$	Propagation Delay (static phase offset)	TCLK to FB_IN, same VDD, does not include jitter	-100	-	100	pS
$t_{sk(O)}$	Output-to-Output Skew	Skew within Bank	-	-	150	pS
$t_{sk(B)}$	Bank-to-Bank Skew	Banks at same voltage, same frequency	-	-	150	pS
		Banks at same voltage, different frequency	-	-	225	
		Banks at different voltage	-	-	250	
$t_{PLZ, HZ}$	Output Disable Time		-	-	10	nS
$t_{PZL, ZH}$	Output Enable Time		-	-	10	nS
BW	PLL Closed Loop Bandwidth (-3dB)	VCO_SEL = 0	-	0.5 - 1.0	-	MHz
		VCO_SEL = 1	-	1.0 - 2.0	-	
$t_{JIT(CC)}$	Cycle-to-Cycle Jitter	Same frequency	-	-	150	pS
		Multiple frequencies	-	-	300	
$t_{JIT(PER)}$	Period Jitter		-	-	100	pS
$t_{JIT(\phi)}$	I/O Phase Jitter	I/O at same VDD	-	-	150	pS
t_{LOCK}	Maximum PLL Lock Time		-	-	1	mS

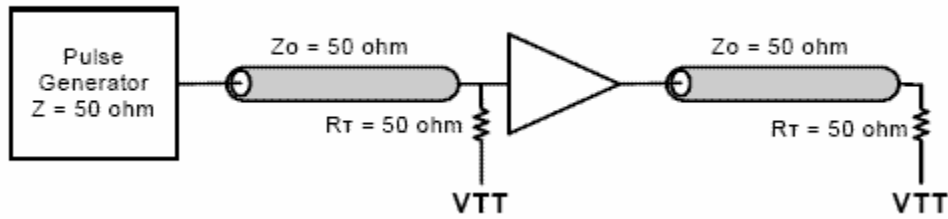

Figure 1. AC Test Reference for VDD = 3.3V / 2.5V

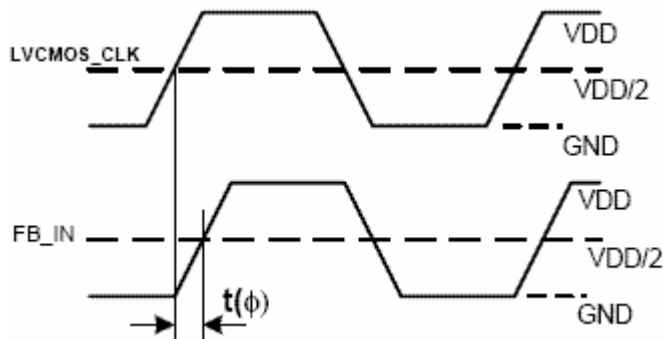

Figure 2. Propagation Delay $t_{(\phi)}$, Static Phase Offset

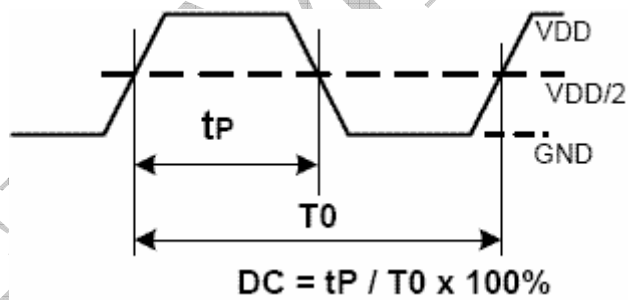

Figure 3. Output Duty Cycle (DC)

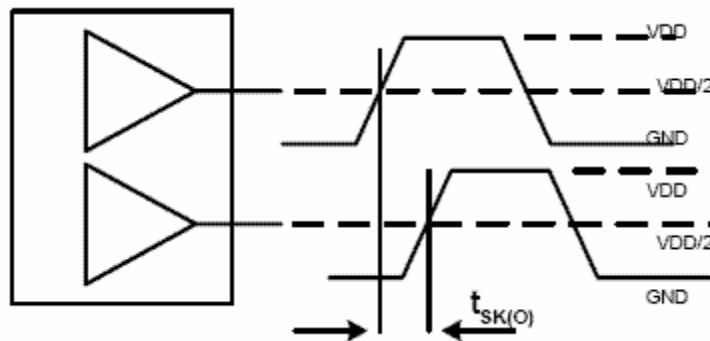

Figure 4. Output-to-Output Skew, $t_{sk(O)}$



rev 0.3

Package Information

52-lead TQFP Package

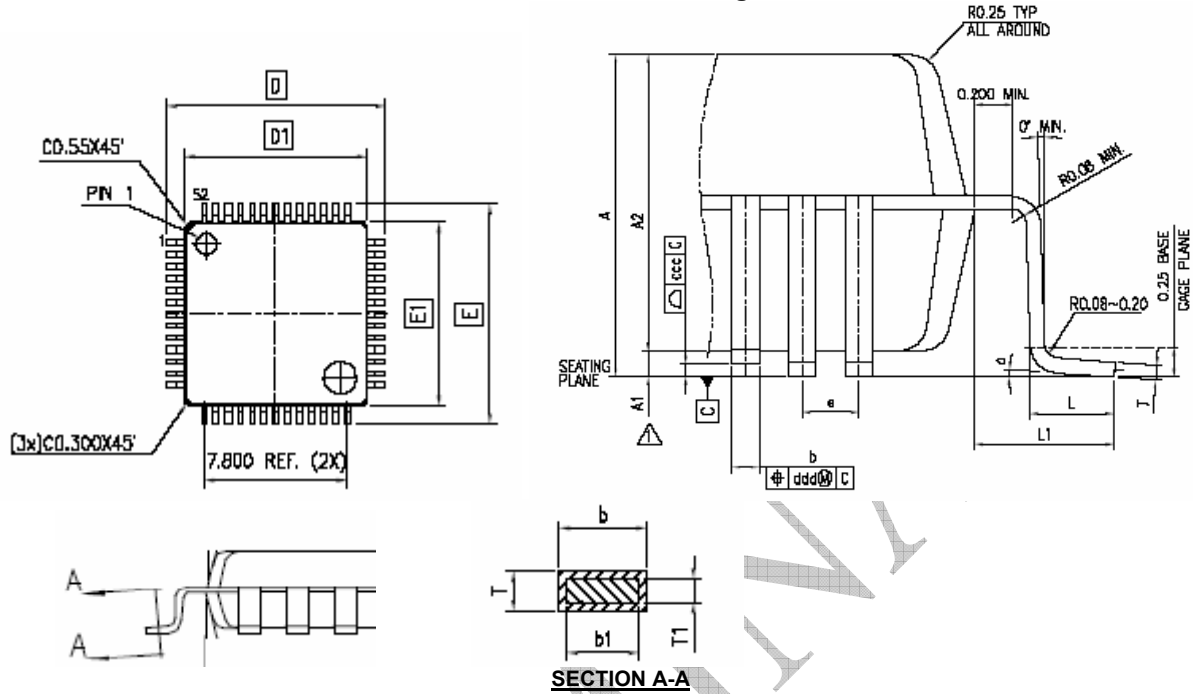

Symbol	Dimensions			
	Inches		Millimeters	
	Min	Max	Min	Max
A	0.0472	...	1.2
A1	0.0020	0.0059	0.05	0.15
A2	0.0374	0.0413	0.95	1.05
D	0.4646	0.4803	11.8	12.2
D1	0.3898	0.3976	9.9	10.1
E	0.4646	0.4803	11.8	12.2
E1	0.3898	0.3976	9.9	10.1
L	0.0177	0.0295	0.45	0.75
L1	0.03937 REF		1.00 REF	
T	0.0035	0.0079	0.09	0.2
T1	0.0038	0.0062	0.097	0.157
b	0.0102	0.0150	0.26	0.38
b1	0.0106	0.0130	0.27	0.33
R0	0.0031	0.0079	0.08	0.2
a	0°	7°	0°	7°
e	0.0256 BASE		0.65 BASE	



Alliance Semiconductor Corporation
2575, Augustine Drive,
Santa Clara, CA 95054
Tel# 408-855-4900
Fax: 408-855-4999
www.alsc.com

Copyright © Alliance Semiconductor
All Rights Reserved
Part Number: ASM5I9775A
Document Version: 0.3

Note: This product utilizes US Patent # 6,646,463 Impedance Emulator Patent issued to Alliance Semiconductor, dated 11-11-2003

© Copyright 2003 Alliance Semiconductor Corporation. All rights reserved. Our three-point logo, our name and Intelliwatt are trademarks or registered trademarks of Alliance. All other brand and product names may be the trademarks of their respective companies. Alliance reserves the right to make changes to this document and its products at any time without notice. Alliance assumes no responsibility for any errors that may appear in this document. The data contained herein represents Alliance's best data and/or estimates at the time of issuance. Alliance reserves the right to change or correct this data at any time, without notice. If the product described herein is under development, significant changes to these specifications are possible. The information in this product data sheet is intended to be general descriptive information for potential customers and users, and is not intended to operate as, or provide, any guarantee or warranty to any user or customer. Alliance does not assume any responsibility or liability arising out of the application or use of any product described herein, and disclaims any express or implied warranties related to the sale and/or use of Alliance products including liability or warranties related to fitness for a particular purpose, merchantability, or infringement of any intellectual property rights, except as express agreed to in Alliance's Terms and Conditions of Sale (which are available from Alliance). All sales of Alliance products are made exclusively according to Alliance's Terms and Conditions of Sale. The purchase of products from Alliance does not convey a license under any patent rights, copyrights; mask works rights, trademarks, or any other intellectual property rights of Alliance or third parties. Alliance does not authorize its products for use as critical components in life-supporting systems where a malfunction or failure may reasonably be expected to result in significant injury to the user, and the inclusion of Alliance products in such life-supporting systems implies that the manufacturer assumes all risk of such use and agrees to indemnify Alliance against all claims arising from such use.